



SIMPLEX VERTICAL TANK MOUNTED DRY CLAW VACUUM SYSTEM 2 - 5 HP

The EMSE CORPORATION tank mounted vacuum system is a completely packaged assembly featuring a high efficiency dry claw vacuum pump, UL listed control cabinet, an ASME receiver and the accessories required to meet and exceed the current code requirements.

All components are piped and wired to single-point service connections. The only field connections are air intake, air discharge and power at the control panel. All interconnecting piping as well as wiring is complete and operationally tested prior to shipment. Liquid tight conduit, fittings and junction boxes are provided for all control and power wiring.

VACUUM PUMPS

The medical vacuum pump is continuous duty, high efficiency, oil-less, frictionless compression claw type, with an intake filter. Each vacuum pump is driven by a 3 phase, 60 cycle, TEFC NEMA C-face motor. Each vacuum pump is supplied with an inlet check valve, inlet isolation valve, safety relief valve, inlet filter, vacuum switch, high discharge temperature switch, inlet and discharge flexible connectors and a shut-off cock for the gauge and vacuum switch.

RECEIVER

The system includes a vacuum receiver of ASME construction rated for 200PSI MWP. The tank is equipped with a vacuum gauge, valved by-pass and manual tank drain.

CONTROL PANEL

The system includes a UL listed control panel in a NEMA 12 enclosure. The panel includes the following standard accessories: externally operable circuit breaker with a door interlock, control circuit transformer with fused primary and secondary coils, H-O-A switch, run light, hour meter, magnetic starter with 3 leg overload protection and reset switch and minimum run timer to prevent short cycle operation.

Local audible and visual alarms are provided and the alarm includes an indicating light and horn. The audible alarm can be cancelled with the "Silence" button. The visual alarm remains energized until the problem is corrected. Each alarm function includes dry contacts for connection to the master alarm. All control and alarm functions remain energized while any vacuum pump remains electrically on-line.

A field adjustable control switch is pre-set to operate the vacuum pump between 19" Hg and 23" Hg.

The medical vacuum system and its component parts undergo a complete electric and pneumatic test prior to shipment.

EMSE Standard Control Panel: 4.3” Touchscreen HMI

The control system provides automatic lead/lag sequencing and automatic alternation of all vacuum pumps based on first-on/first-off principle with provision for simultaneous operation if required.

The control panel features:

- A 4.3” Touchscreen with screen displays inclusive of:
 - Service alerts, runtime hour meters, system status, system vacuum level
 - Visual/audible alarm indications with isolated contacts for all standard remote alarms
 - Event log recording alarms and system activity
- NEMA 12 control panel enclosure
- Circuit breaker disconnects for each motor with external operators
- Full voltage motor starters with overload protection
- Vacuum level controlled by a vacuum transducer
- Vacuum switches are provided as a back-up to the vacuum transducer in the event of failure
 - **Options:**
 - 24V Control Circuit
 - VFD
 - Ethernet connectivity and embedded web page for remote monitoring of alarms and system status
 - BacNet Gateway
 - Modbus

WARRANTY

The Medical Vacuum system is guaranteed by the manufacturer for a period of 30 months from date of shipment from the factory or 24 months from date of start-up, (whichever comes first) against defects in design, materials, or construction.

Optional System Accessories

- | | |
|--|---|
| <input type="checkbox"/> Oxygen Assured Vacuum Pumps | <input type="checkbox"/> Exhaust Muffler |
| <input type="checkbox"/> Rust protection receiver lining | <input type="checkbox"/> Receiver gauge glass |
| <input type="checkbox"/> Galvanized receiver | <input type="checkbox"/> Bacteria inlet filter with flask |

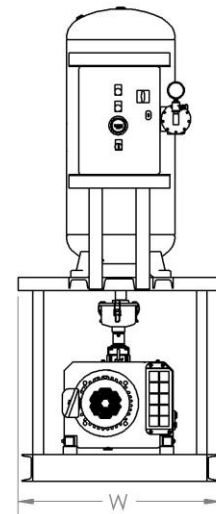
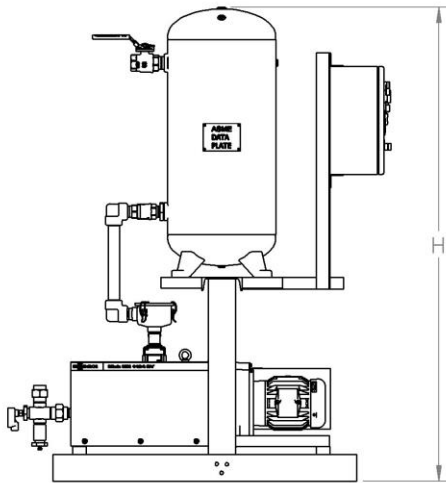
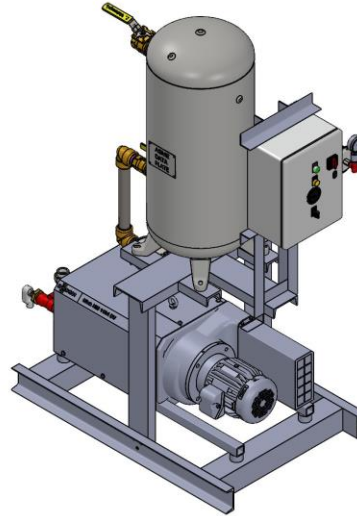
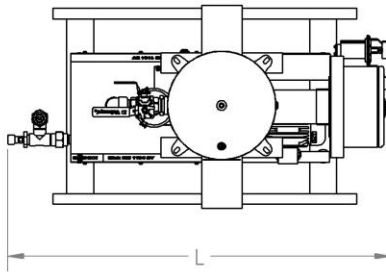

Model	HP (each)	System Capacity at 19" Hg (SCFM)	Suction NPT	Exhaust NPT	Tank (gallon)	Dimensions (inches)			Weight (lbs.)	Sound level dB(A)	System FLA		
						L	W	H			208V	230V	460V
1SCB2T30V-TT	2	16	1 1/2"	1"	30	57	30	71	1470	70	11	11	7
1SCB3T30V-TT	3	21	1 1/2"	1"	30	57	30	71	1490	70	13	13	9
1SCB4T30V-TT	4	29	1 1/2"	1"	30	57	30	71	1488	79	16	15	10
1SCB5T30V-TT	5	38	1 1/2"	1"	30	57	30	71	1490	79	20	18	11

Notes:

1. Capacity shown is system capacity, with one pump in reserve per NFPA 99; values assume 60Hz motors.
2. To convert Free Air Capacity (SCFM) to Expanded Air Capacity (ACFM): at 19" Hg multiply SCFM by 2.74
3. Maximum ambient temperature: 100° F for standard systems, 90° F if equipped with variable speed drive
4. Dimensions are subject to change
5. Allow 36" clearance in front of control panel and 24" clearance on all other sides
6. System is available in a Vertical or Horizontal Configuration with 30 & 60 gallon tanks – consult factory for specs