



Medical Air & Vacuum System Specialists

MEDICAL VACUUM SYSTEM, DUPLEX TANK-MOUNTED, LUBRICATED ROTARY VANE

10 HP

The EMSE CORPORATION Medical vacuum system is a completely packaged NFPA 99 and NEC compliant assembly featuring oil-lubricated rotary vane vacuum pumps, U.L. listed control cabinet, an ASME receiver and the accessories required to meet and exceed the current code requirements.

All components are piped and wired to single-point service connections. The only field connections are air intake, air discharge and power at the control panel. All interconnecting piping and wiring is complete and operationally tested prior to shipment. Liquid tight conduit, fittings and junction boxes are provided for all control and power wiring.

VACUUM PUMPS

The Medical vacuum pumps are continuous duty, rotary vane, air-cooled, equipped with non-asbestos vanes, having a minimum life of 40,000 hours. The pumps are provided with a full recirculated oil supply. The oil separation consists of four stages of oil and smoke eliminators, capable of removing 99.9+% of oil and smoke particles from the exhaust. Each vacuum pump is driven by a 3 phase, 60 cycle, TEFC NEMA C-face, motor.

Each vacuum pump is supplied with an inlet check valve, inlet isolation valve, built-in anti-suck-back valve, inlet filter screen, oil sight gauge, oil drain valve, exhaust pressure gauge, vacuum switch, high discharge temperature switch, inlet and discharge flexible connectors and a shut-off cock for gauge and vacuum switches.

RECEIVER

The system includes a vacuum receiver of ASME construction rated for 200 PSI MWP. The tank includes a vacuum gauge, valved by-pass and manual tank drain.

CONTROL PANEL

The UL listed control panel is supplied in a NEMA 12 enclosure and includes short circuit, single phase and thermal overload protection. Externally operable circuit breakers with a door interlock, control circuit transformers with fused primary and secondary coils, HOA switches, magnetic starters with 3 leg overload protection and reset switches are standard.

The programmable logic controller provides automatic alternation and lead-lag control with the option to select either one of the pumps as a permanent lead for periods of pump maintenance. It includes minimum run timers to prevent short cycle operation. Human machine interface (HMI) display includes pump run indication, accumulated run time and alarm conditions.

Local "Backup in use" audible and visual alarms are provided per NFPA 99. The audible alarm can be acknowledged with the "Silence" button. The visual alarm will stay on until manually reset. All controls and alarms will function even if one of the pumps is shut down for maintenance or repairs. The panel includes a set of dry contacts for connection to the master alarm.

Vacuum pumps are controlled via a vacuum transducer. Lead / Lag back-up vacuum switches are included in the event of PLC or transducer failure.



Medical Air & Vacuum System Specialists

EMSE Standard Control Panel: 4.3” Touchscreen HMI

The control system provides automatic lead/lag sequencing and automatic alternation of all vacuum pumps based on first-on/first-off principle with provision for simultaneous operation if required.

The control panel features:

- A 4.3” Touchscreen with screen displays inclusive of:
 - Service alerts, runtime hour meters, system status, system vacuum level
 - Visual/audible alarm indications with isolated contacts for all standard remote alarms
 - Event log recording alarms and system activity
- NEMA 12 control panel enclosure
- Circuit breaker disconnects for each motor with external operators
- Full voltage motor starters with overload protection
- Vacuum level controlled by a vacuum transducer
- Vacuum switches are provided as a back-up to the vacuum transducer in the event of failure
 - **Options:**
 - 24V Control Circuit
 - VFD
 - Ethernet connectivity and embedded web page for remote monitoring of alarms and system status
 - BacNet Gateway
 - Modbus

OPTIONAL:

EMSE Premium Control Panel, 7” Touchscreen HMI:

The control system provides automatic lead/lag sequencing and automatic alternation of all vacuum pumps based on first-on/first-off principle with provision for simultaneous operation if required.

The control panel features:

- A 7” Touchscreen HMI with screen displays inclusive of:
 - Service alerts, runtime hour meters, system status, system vacuum level
 - Visual/audible alarm indications with isolated contacts for all standard remote alarms
 - Event log recording alarms and system activity
- NEMA 12 control panel enclosure
- Circuit breaker disconnects for each motor with external operators
- Full voltage motor starters with overload protection
- Vacuum level controlled by vacuum transducer.
- Vacuum switches provided as a back-up to the vacuum transducer in the event of failure
 - **Options:**
 - 24V Control Circuit
 - VFD
 - Ethernet connectivity and embedded web page for remote monitoring of alarms and system status
 - BacNet Gateway
 - Modbus

WARRANTY

The Medical Vacuum system is guaranteed by the manufacturer for a period of 30 months from date of shipment from the factory or 24 months from date of start-up, (whichever comes first) against defects in design, materials, or construction.

Optional System Accessories

- | | |
|--|---|
| <input type="checkbox"/> Oxygen Assured Vacuum Pumps | <input type="checkbox"/> Exhaust Muffler |
| <input type="checkbox"/> Rust protection receiver lining | <input type="checkbox"/> Receiver gauge glass |
| <input type="checkbox"/> Galvanized receiver | <input type="checkbox"/> Bacteria inlet filter with flask |

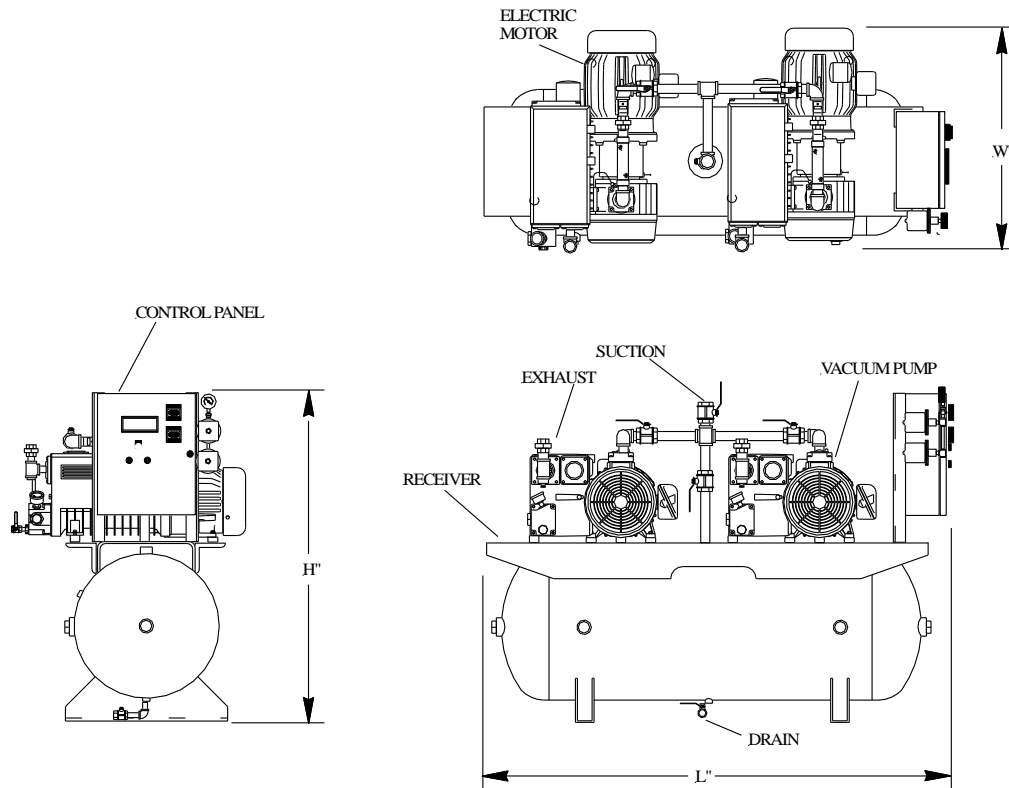

System Model Number	HP (each)	Capacity at 19" Hg (SCFM)		Inlet NPT	Outlet NPT	Tank (gallon)	Dimensions (inches)			Weight (lbs.)	Sound level dB(A)	System FLA		
		Pump	System				L	W	H			208V	230V	460V
1DRB10T120	10	65	130	2"	2"	120	89	48	66	1920	76	78	76	40
1DRB10T200	10	65	130	2"	2"	200	89	48	66	2120	76	78	76	40
1DRB10T240	10	65	130	2"	2"	240	90	50	72	2285	76	78	76	40
1DRB10HT120	10	77	154	2"	2"	120	89	48	66	1920	76	78	76	40
1DRB10HT200	10	77	154	2"	2"	200	89	48	66	2120	76	78	76	40
1DRB10HT240	10	77	154	2"	2"	240	90	50	72	2285	76	78	76	40

NOTES:

1. Capacity show is with reserve pump on stand-by, per NFPA 99
2. To convert free air capacity (SCFM) to expanded air capacity (ACFM), multiply SCFM by 2.74
3. Maximum ambient temperature: 100°F for standard systems
4. Allow 36 in front of control panel and 24 inches around all other sides
5. Dimensions are subject to change