



Medical Air & Vacuum System Specialists

INDUSTRIAL VACUUM SYSTEM, DUPLEX TANK-MOUNTED, LUBRICATED ROTARY VANE

1 – 7.5 HP

The EMSE CORPORATION Industrial vacuum system is a completely packaged assembly featuring oil-lubricated rotary vane vacuum pumps, U.L. listed control cabinet, an ASME receiver and the accessories required to meet and exceed the current code requirements.

All components are piped and wired to single-point service connections. The only field connections are air intake, air discharge and power at the control panel. All interconnecting piping and wiring is complete and operationally tested prior to shipment. Liquid tight conduit, fittings and junction boxes are provided for all control and power wiring.

VACUUM PUMPS

The Industrial vacuum pumps are continuous duty, rotary vane, air-cooled, equipped with non-asbestos vanes, having a minimum life of 40,000 hours. The pumps are provided with a full recirculated oil supply. The oil separation consists of four stages of oil and smoke eliminators, capable of removing 99.9+% of oil and smoke particles from the exhaust. Each vacuum pump is driven by a 3 phase, 60 cycle, TEFC NEMA C-face, motor.

Each vacuum pump is supplied with an inlet check valve, inlet isolation valve, built-in anti-suck-back valve, inlet filter screen, oil sight gauge, oil drain valve, exhaust pressure gauge, high discharge temperature switch, inlet and discharge flexible connectors and a shut-off cock for gauge and vacuum switches.

RECEIVER

The system includes a vacuum receiver of ASME construction rated for 200 PSI MWP. The tank includes a vacuum gauge, valved by-pass and manual tank drain.

CONTROL PANEL

The system includes a UL listed control panel in a NEMA 12 enclosure. The panel includes the following standard accessories for **each** pump: externally operable circuit breaker with a door interlock, control circuit transformer with fused primary and secondary coils, H-O-A switch, run light, hour meter, magnetic starter with 3 leg overload protection and reset switch and minimum run timer to prevent short cycle operation.

A plug-in type programmable controller with removable terminals allows quick and easy replacement in the field. The system is designed to function even if the PLC fails. If one of the pumps is out of service the system control shall omit that pump from the alternating cycle, automatically alternating between the remaining pumps. The system shall revert to normal automatic alternation when the condition is corrected. The system is also supplied with forced time alternation in the event the pump is unable to satisfy the demand in 30 minutes.

Local audible and visual alarms are provided per NFPA 99. The alarm includes an indicating light and horn. The audible alarm can be cancelled with the "Silence" button. The visual alarm remains energized until the problem is corrected. Each alarm function includes dry contacts for connection to the master alarm.

All control and alarm functions remain energized while any vacuum pump remains electrically on-line.

The vacuum pumps are controlled via a vacuum transducer. Lead / Lag back-up vacuum switches are included in the event of PLC or transducer failure.

The Industrial Vacuum system and its component parts undergo a complete electric and pneumatic test prior to shipment.

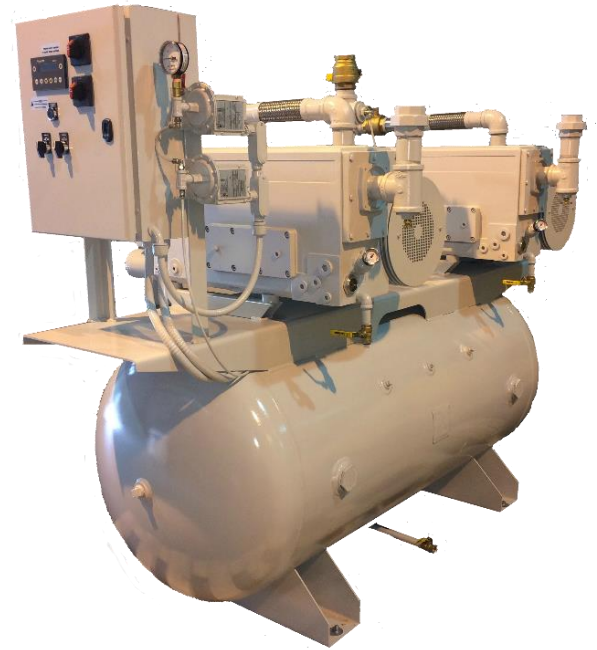



Medical Air & Vacuum System Specialists

INDUSTRIAL VACUUM SYSTEM, DUPLEX TANK-MOUNTED, LUBRICATED ROTARY VANE

1 – 7.5 HP

EMSE Standard Control Panel: 4.3” Touchscreen HMI

The control system provides automatic lead/lag sequencing and automatic alternation of all vacuum pumps based on first-on/first-off principle with provision for simultaneous operation if required.

The control panel features:

- A 4.3” Touchscreen with screen displays inclusive of:
 - Service alerts, runtime hour meters, system status, system vacuum level
 - Visual/audible alarm indications with isolated contacts for all standard remote alarms
 - Event log recording alarms and system activity
- NEMA 12 control panel enclosure
- Circuit breaker disconnects for each motor with external operators
- Full voltage motor starters with overload protection
- Vacuum level controlled by a vacuum transducer
- Vacuum switches are provided as a back-up to the vacuum transducer in the event of failure
 - **Options:**
 - 24V Control Circuit
 - VFD
 - Ethernet connectivity and embedded web page for remote monitoring of alarms and system status
 - BacNet Gateway
 - Modbus

OPTIONAL:

EMSE Premium Control Panel, 7” Touchscreen HMI:

The control system provides automatic lead/lag sequencing and automatic alternation of all vacuum pumps based on first-on/first-off principle with provision for simultaneous operation if required.

The control panel features:

- A 7” Touchscreen HMI with screen displays inclusive of:
 - Service alerts, runtime hour meters, system status, system vacuum level
 - Visual/audible alarm indications with isolated contacts for all standard remote alarms
 - Event log recording alarms and system activity
- NEMA 12 control panel enclosure
- Circuit breaker disconnects for each motor with external operators
- Full voltage motor starters with overload protection
- Vacuum level controlled by vacuum transducer.
- Vacuum switches provided as a back-up to the vacuum transducer in the event of failure
 - **Options:**
 - 24V Control Circuit
 - VFD
 - Ethernet connectivity and embedded web page for remote monitoring of alarms and system status
 - BacNet Gateway
 - Modbus

WARRANTY

The Industrial Vacuum system is guaranteed by the manufacturer for a period of 30 months from date of shipment from the factory or 24 months from date of start-up, (whichever comes first) against defects in design, materials, or construction.

Optional System Accessories

- | | |
|--|---|
| <input type="checkbox"/> Oxygen Assured Vacuum Pumps | <input type="checkbox"/> Exhaust Muffler |
| <input type="checkbox"/> Rust protection receiver lining | <input type="checkbox"/> Receiver gauge glass |
| <input type="checkbox"/> Galvanized receiver | <input type="checkbox"/> Bacteria inlet filter with flask |

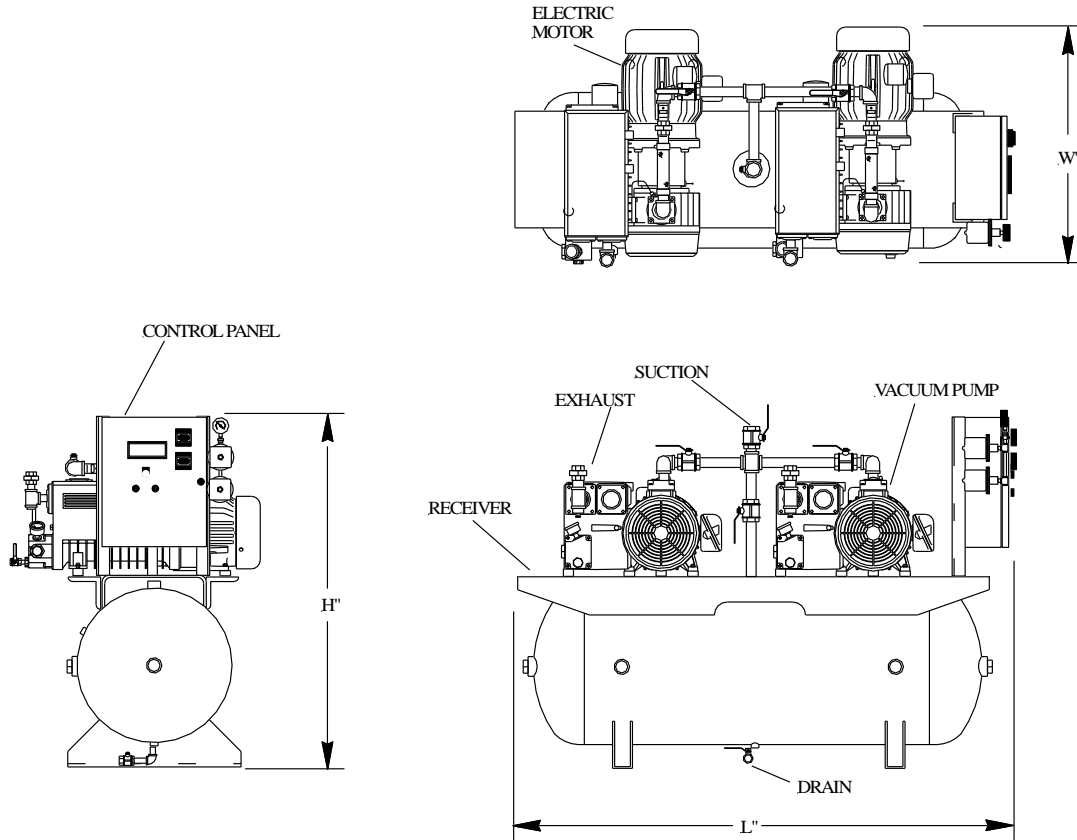

System Model Number	HP	Capacity at 19" Hg (SCFM)		Inlet NPT	Outlet NPT	Tank (gallon)	Dimensions (inches)			Weight (lbs.)	Sound level dB(A)	System FLA		
		Pump	System				L	W	H			208V	230V	460V
1DRB1T60-IND	1	5.1	10.2	3/4"	3/4"	60	61	30	52	640	66	9	9	6
1DRB1T80-IND	1	5.1	10.2	3/4"	3/4"	80	72	30	52	680	66	9	9	6
1DRB1.5T60-IND	1.5	7	14	1 1/4"	1 1/4"	60	61	30	52	700	66	9	9	6
1DRB1.5T80-IND	1.5	7	14	1 1/4"	1 1/4"	80	72	30	52	840	66	9	9	6
1DRB2T60-IND	2	11	22	1 1/4"	1 1/4"	60	61	30	52	750	67	17	17	10
1DRB2T80-IND	2	11	22	1 1/4"	1 1/4"	80	72	30	52	860	67	17	17	10
1DRB2T120-IND	2	11	22	1 1/4"	1 1/4"	120	77	30	56	950	67	17	22	13
1DRB3T80-IND	3	17	34	1 1/4"	1 1/4"	80	75	32	54	875	68	23	22	13
1DRB3T120-IND	3	17	34	1 1/4"	1 1/4"	120	77	32	56	975	68	23	22	13
1DRB5T80-IND	5	26	52	1 1/4"	1 1/4"	80	75	36	56	1045	70	36	34	19
1DRB5T120-IND	5	26	52	1 1/4"	1 1/4"	120	77	36	56	1145	70	36	34	19
1DRB5HT80-IND	5	37	74	2"	2"	80	75	36	56	1375	72	36	34	19
1DRB5HT120-IND	5	37	74	2"	2"	120	77	36	56	1475	72	36	34	19
1DRB7.5T120-IND	7.5	52	104	2"	2"	120	80	46	66	1620	74	54	55	30
1DRB7.5T200-IND	7.5	52	104	2"	2"	200	89	46	66	1820	74	54	55	30

NOTES:

1. Capacity show is with both pumps running
2. To convert free air capacity (SCFM) to expanded air capacity (ACFM), multiply SCFM by 2.74
3. Maximum ambient temperature: 100°F for standard systems
4. Allow 36 in front of control panel and 24 inches around all other sides
5. Dimensions are subject to change