

The EMSE CORPORATION tank mounted Medical Vacuum system is a completely packaged NFPA 99 and NEC compliant assembly featuring high efficiency dry rotary vane vacuum pumps, U.L. listed control cabinet, an ASME receiver and the accessories required to meet and exceed the current code requirements.

All components are piped and wired to single-point service connections. The only field connections are air intake, air discharge and power at the control panel.

All interconnecting piping as well as wiring is complete and operationally tested prior to shipment. Liquid tight conduit, fittings and junction boxes are provided for all control and power wiring.

### **VACUUM PUMPS**

The medical vacuum pumps are continuous duty, oil-less, rotary vane, air-cooled.

Each vacuum pump is driven by a 3 phase, 60 cycle, TEFC NEMA C-face motor.

Each pump is supplied with an inlet check valve, inlet isolation valve, inlet filter screen, vacuum switch, inlet and discharge flexible connectors and a shut-off cock for gauge and vacuum switches.

### **RECEIVER**

The system includes a vacuum receiver of ASME construction rated for 200PSI MWP. The tank is equipped with a vacuum gauge, valved by-pass and manual tank drain.

### **CONTROL PANEL**

The UL listed control panel is supplied in a NEMA 12 enclosure and includes short circuit, single phase and thermal overload protection. Externally operable circuit breaker with a door interlock, control circuit transformer with fused primary and secondary coils, H-O-A switch, magnetic starter with 3 leg overload protection and reset switch are standard.

The Programmable Logic Controller provided automatic alternation and lead-lag control with the option to select either one of the pumps as a permanent lead for periods of pump maintenance. It includes minimum run timers to prevent short cycle operation. Human Machine Interface (HMI) display includes pump run indication, accumulated run time and alarm conditions.

Local "Backup in use" audible and visual alarms are provided per NFPA 99. The audible alarm can be acknowledged with the "Silence" button. The visual alarm will stay on until manually rest.

All control and alarms will function even if one of the pumps is shut down for maintenance or repairs. The panel includes a set of dry contacts for connection to the master alarm.

Vacuum pumps are controlled via a vacuum transducer. Lead / Lag back-up vacuum switches are included in the event of PLC or transducer failure.

### **EMSE Standard Control Panel: 4.3” Touchscreen HMI**

The control system provides automatic lead/lag sequencing and automatic alternation of all vacuum pumps based on first-on/first-off principle with provision for simultaneous operation if required.

The control panel features:

- A 4.3” Touchscreen with screen displays inclusive of:
  - Service alerts, runtime hour meters, system status, system vacuum level
  - Visual/audible alarm indications with isolated contacts for all standard remote alarms
  - Event log recording alarms and system activity
- NEMA 12 control panel enclosure
- Circuit breaker disconnects for each motor with external operators
- Full voltage motor starters with overload protection
- Vacuum level controlled by a vacuum transducer
- Vacuum switches are provided as a back-up to the vacuum transducer in the event of failure
  - **Options:**
    - 24V Control Circuit
    - VFD
    - Ethernet connectivity and embedded web page for remote monitoring of alarms and system status
    - BacNet Gateway
    - Modbus

### **OPTIONAL:**

#### **EMSE Premium Control Panel, 7” Touchscreen HMI:**

The control system provides automatic lead/lag sequencing and automatic alternation of all vacuum pumps based on first-on/first-off principle with provision for simultaneous operation if required.

The control panel features:

- A 7” Touchscreen HMI with screen displays inclusive of:
  - Service alerts, runtime hour meters, system status, system vacuum level
  - Visual/audible alarm indications with isolated contacts for all standard remote alarms
  - Event log recording alarms and system activity
- NEMA 12 control panel enclosure
- Circuit breaker disconnects for each motor with external operators
- Full voltage motor starters with overload protection
- Vacuum level controlled by vacuum transducer.
- Vacuum switches provided as a back-up to the vacuum transducer in the event of failure
  - **Options:**
    - 24V Control Circuit
    - VFD
    - Ethernet connectivity and embedded web page for remote monitoring of alarms and system status
    - BacNet Gateway
    - Modbus

### **WARRANTY**

The Medical Vacuum system is guaranteed by the manufacturer for a period of 24 months from the date of start-up or 30 months from the date of shipment (whichever comes first) against defects in design, materials, or construction.

### **Optional System Accessories**

- |                                                          |                                                           |
|----------------------------------------------------------|-----------------------------------------------------------|
| <input type="checkbox"/> Oxygen Assured Vacuum Pumps     | <input type="checkbox"/> Exhaust Muffler                  |
| <input type="checkbox"/> Rust protection receiver lining | <input type="checkbox"/> Receiver gauge glass             |
| <input type="checkbox"/> Galvanized receiver             | <input type="checkbox"/> Bacteria inlet filter with flask |

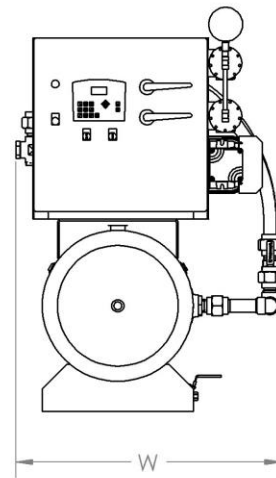
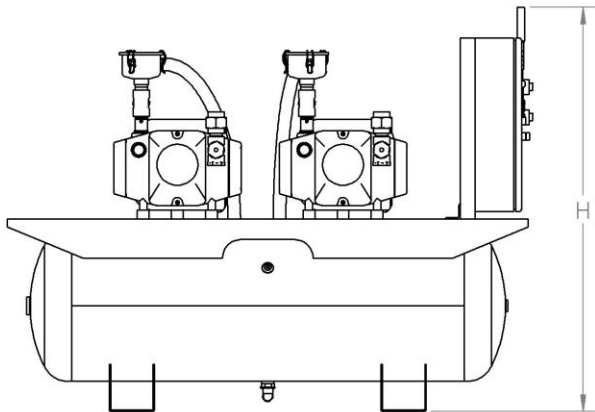
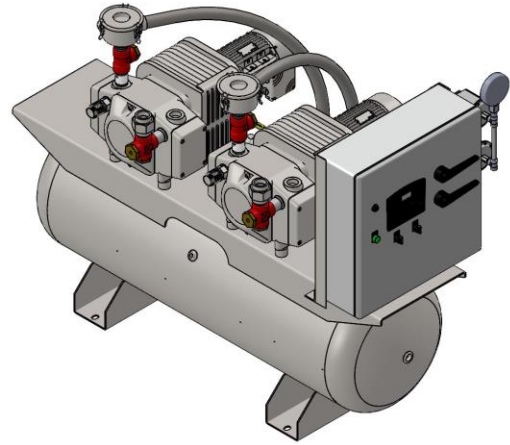
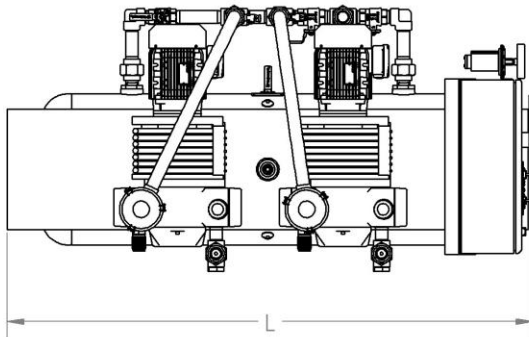

Model	HP (each)	System Capacity SCFM @ 19" Hg		Suction NPT	Exhaust NPT	Tank (Gallon)	Dimensions (inches)			Weight (lbs.)	Sound Level dB(A)	System FLA		
		Pump	System				L	W	H			208V	230V	460V
1DOB1HT60	1	3.5	3.5	1"	1"	60	54	30	52	652	66	10	8.6	4.2
1DOB1.5HT30	1.5	5.3	5.3	1"	1"	30	48	30	52	618	66	12	11	8
1DOB1.5HT60	1.5	5.3	5.3	1"	1"	60	54	30	52	685	66	12	11	8
1DOB1.5HT80	1.5	5.3	5.3	1"	1"	80	72	38	64	710	66	12	11	8
1DOB2HT60	2	8	8	1"	1"	60	54	30	52	716	70	19	18	10
1DOB2HT80	2	8	8	1"	1"	80	72	38	64	743	70	19	18	10

Single Phase pumps - FLA (all pumps running)	HP	115V	230V
	1	35	20
	1.5	43	24
	2.0	52	27

**Notes:**

- Capacity shown is system capacity, with one pump in reserve per NFPA 99; values assume 60Hz motors.
- To convert Free Air Capacity (SCFM) to Expanded Air Capacity (ACFM): at 19" Hg multiply SCFM by 2.74
- Maximum ambient temperature: 100° F for standard systems, 90° F if equipped with variable speed drive
- Dimensions are subject to change
- Allow 36" clearance in front of control panel and 24" clearance on all other sides