

The EMSE CORPORATION stack mounted Medical Vacuum system is a completely packaged NFPA 99 and NEC compliant assembly featuring high efficiency dry claw vacuum pumps, U.L. listed control cabinet, an ASME receiver and the accessories required to meet and exceed the current code requirements.

All components are piped and wired to single-point service connections. The only field connections are air intake, air discharge and power at the control panel.

All interconnecting piping as well as wiring is complete and operationally tested prior to shipment. Liquid tight conduit, fittings and junction boxes are provided for all control and power wiring.

#### **VACUUM PUMPS**

The medical vacuum pumps are continuous duty, high efficiency, oil-less, frictionless compression claw type. Each vacuum pump is driven by a 3 phase, 60 cycle, TEFC NEMA C-face motor. Each vacuum pump is supplied with an inlet check valve, inlet isolation valve, safety relief valve, inlet filter, vacuum switch, high discharge temperature switch, inlet and discharge flexible connectors and a shut-off cock for gauge and vacuum switches.

#### **RECEIVER**

The system includes a vacuum receiver of ASME construction rated for 200PSI MWP. The tank is equipped with a vacuum gauge, three-way valved by-pass and manual tank drain.

#### **CONTROL PANEL**

The system includes a UL listed control panel in a NEMA 12 enclosure. The panel includes the following standard accessories for **each** pump: externally operable circuit breaker with a door interlock, control circuit transformer with fused primary and secondary coils, H-O-A switch, run light, hour meter, magnetic starter with 3 leg overload protection and reset switch and minimum run timer to prevent short cycle operation.

A plug-in type programmable controller with removable terminals allows quick and easy replacement in the field. The system is designed to function even if the PLC fails. If one of the pumps is out of service the system control shall omit that pump from the alternating cycle, automatically alternating between the remaining pumps. The system shall revert to normal automatic alternation when the condition is corrected. The system is also supplied with forced time alternation in the event the pump is unable to satisfy the demand in 30 minutes.

Local "Backup in use" audible and visual alarms are provided per NFPA 99. The alarm includes an indicating light and horn. The audible alarm can be cancelled with the "Silence" button. The visual alarm remains energized until the problem is corrected. Each alarm function includes dry contacts for connection to the master alarm.

All control and alarm functions remain energized while any vacuum pump remains electrically on-line.

The vacuum pumps are controlled via a vacuum transducer. Lead / Lag back-up vacuum switches are included in the event of PLC or transducer failure.

The Medical Vacuum system and its component parts undergo a complete electric and pneumatic test prior to shipment.



Medical Air & Vacuum System Specialists

DUPLEX MEDICAL VACUUM SYSTEM  
STACK MOUNTED DRY CLAW  
2 – 7.5 HP

**EMSE Standard Control Panel: 4.3” Touchscreen HMI**

The control system provides automatic lead/lag sequencing and automatic alternation of all vacuum pumps based on first-on/first-off principle with provision for simultaneous operation if required.

The control panel features:

- A 4.3” Touchscreen with screen displays inclusive of:
  - Service alerts, runtime hour meters, system status, system vacuum level
  - Visual/audible alarm indications with isolated contacts for all standard remote alarms
  - Event log recording alarms and system activity
- NEMA 12 control panel enclosure
- Circuit breaker disconnects for each motor with external operators
- Full voltage motor starters with overload protection
- Vacuum level controlled by a vacuum transducer
- Vacuum switches are provided as a back-up to the vacuum transducer in the event of failure
  - **Options:**
    - 24V Control Circuit
    - VFD
    - Ethernet connectivity and embedded web page for remote monitoring of alarms and system status
    - BacNet Gateway
    - Modbus

**OPTIONAL:**

**EMSE Premium Control Panel, 7” Touchscreen HMI:**

The control system provides automatic lead/lag sequencing and automatic alternation of all vacuum pumps based on first-on/first-off principle with provision for simultaneous operation if required.

The control panel features:

- A 7” Touchscreen HMI with screen displays inclusive of:
  - Service alerts, runtime hour meters, system status, system vacuum level
  - Visual/audible alarm indications with isolated contacts for all standard remote alarms
  - Event log recording alarms and system activity
- NEMA 12 control panel enclosure
- Circuit breaker disconnects for each motor with external operators
- Full voltage motor starters with overload protection
- Vacuum level controlled by vacuum transducer.
- Vacuum switches provided as a back-up to the vacuum transducer in the event of failure
  - **Options:**
    - 24V Control Circuit
    - VFD
    - Ethernet connectivity and embedded web page for remote monitoring of alarms and system status
    - BacNet Gateway
    - Modbus

**WARRANTY**

The Medical Vacuum system is guaranteed by the manufacturer for a period of 30 months from date of shipment from the factory or 24 months from date of start-up, (whichever comes first) against defects in design, materials, or construction.

**Optional System Accessories**

- |  |   |
|--|---|
| <input type="checkbox"/> Oxygen Assured Vacuum Pumps     | <input type="checkbox"/> Exhaust Muffler                  |
| <input type="checkbox"/> Rust protection receiver lining | <input type="checkbox"/> Receiver gauge glass             |
| <input type="checkbox"/> Galvanized receiver             | <input type="checkbox"/> Bacteria inlet filter with flask |



Medical Air & Vacuum System Specialists

DUPLEX MEDICAL VACUUM SYSTEM  
 STACK MOUNTED DRY CLAW  
 2 – 7.5 HP

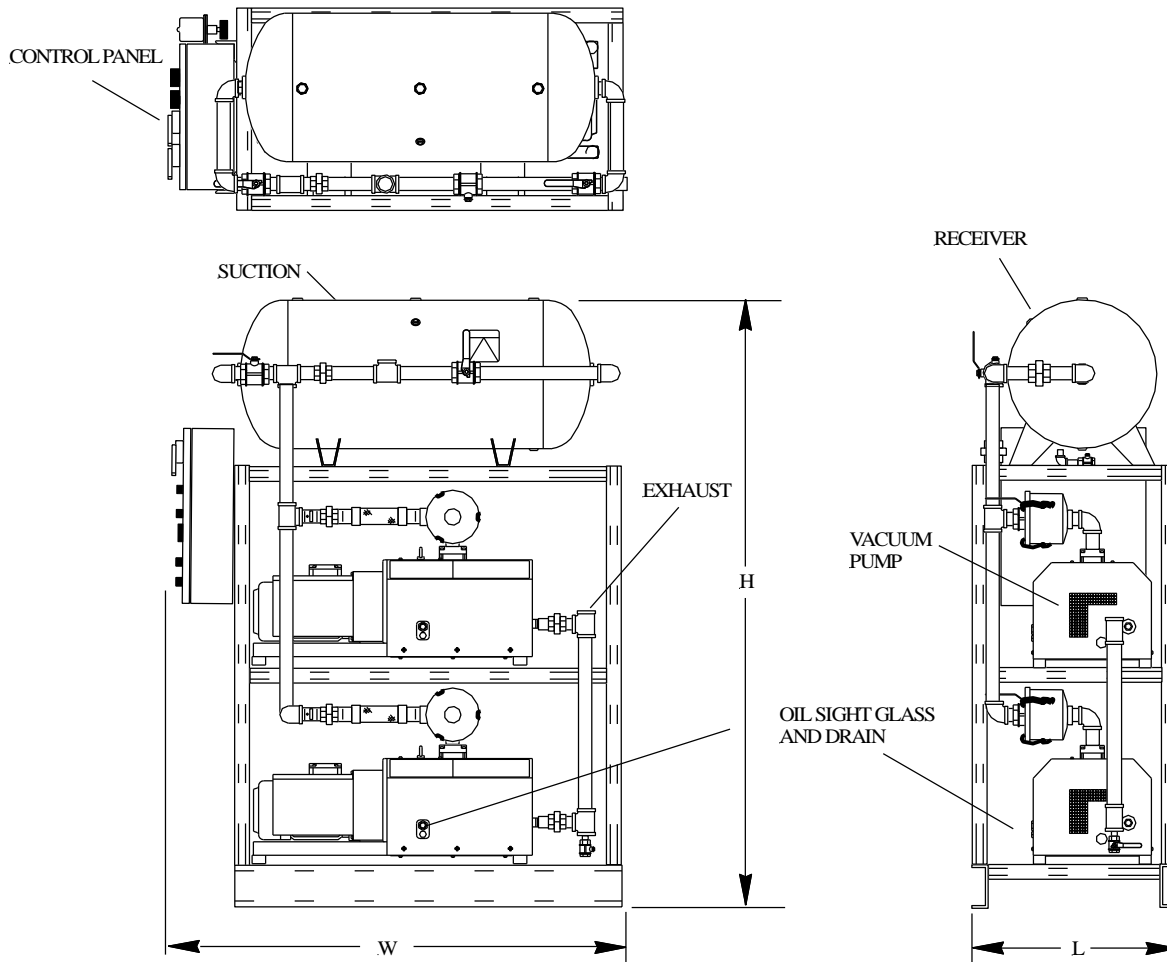

System Model Number	HP (each)	System Capacity (SCFM) @ 19" Hg	Suction NPT	Exhaust NPT	Tank (gallon)	Dimensions (inches)			Weight (lbs.)	Sound Level dB (A)	System (FLA)		
						L	W	H			208V	230V	460V
1DCB2S60H	2	16	1 1/4"	1 1/4"	60	32	62	85	1780	70	20	20	12
1DCB3S60H	3	21	1 1/4"	1 1/4"	60	32	62	85	1800	70	25	25	15
1DCB4S60H	4	29	1 1/4"	1 1/4"	60	32	62	85	1800	79	30	28	17
1DCB5S60H	5	38	1 1/4"	1 1/4"	60	32	62	85	1800	79	37	34	20
1DCB6.4S60H	6.4	52	2"	1 1/4"	60	34	80	85	2000	79	45	43	24
1DCB7.5S60H	7.5	65	2"	1 1/4"	60	34	80	85	2100	79	51	48	27

Notes:

- Capacity shown is system capacity, with one pump in reserve per NFPA 99; values assume 60Hz motors.
- To convert Free Air Capacity (SCFM) to Expanded Air Capacity (ACFM): at 19" Hg multiply SCFM by 2.74
- Maximum ambient temperature: 100° F for standard systems, 90° F if equipped with variable speed drive
- Dimensions are subject to change
- Allow 36" clearance in front of control panel and 24" clearance on all other sides